

LÍNEA  
**ILUMINACIÓN**

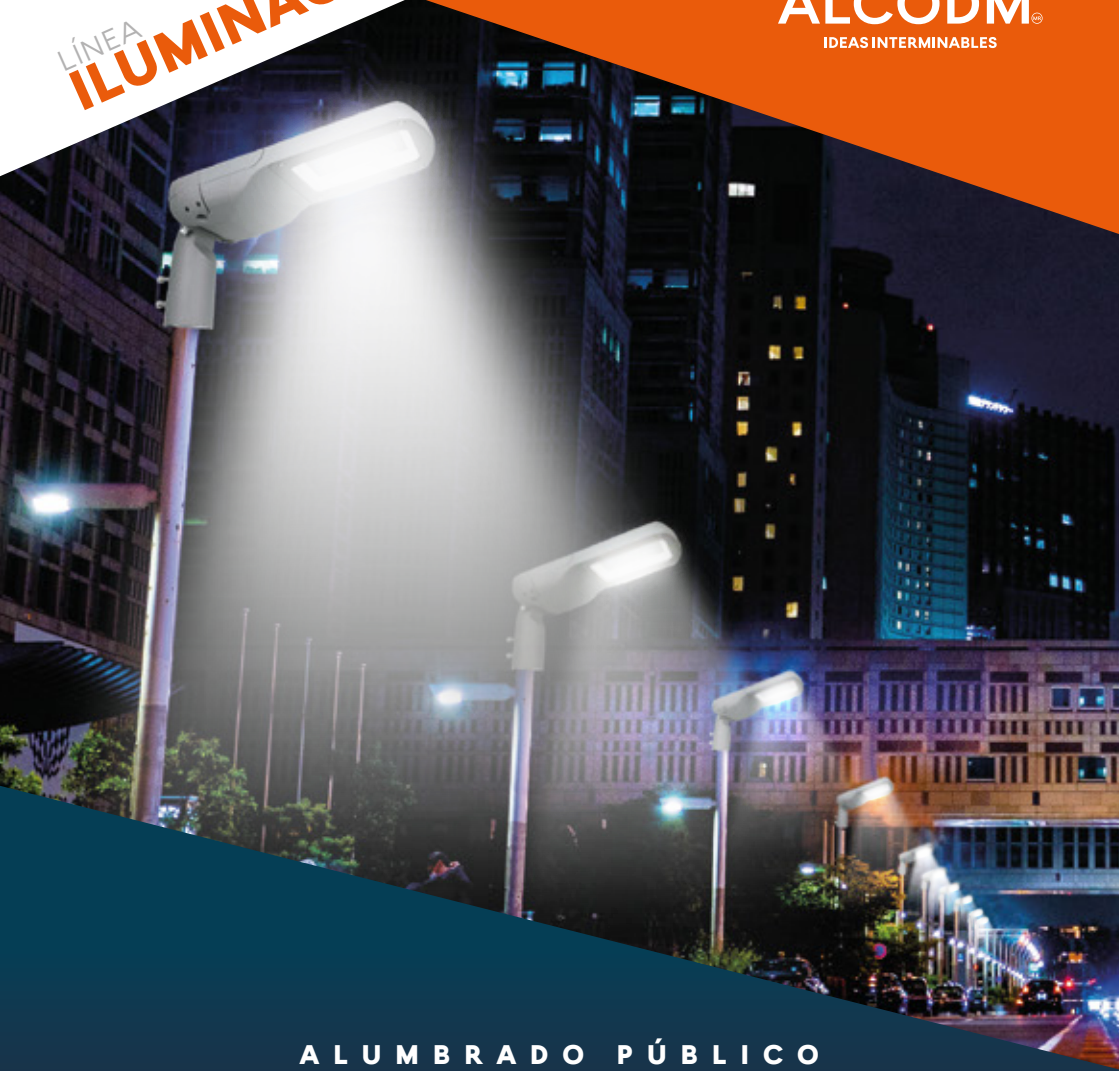

**ALCODM**<sup>®</sup>  
IDEAS INTERMINABLES



ALUMBRADO PÚBLICO

**BOREALIS**

SISTEMA CERTIFICADO  
**ISO** 9001:2015

# ALUMBRADO PÚBLICO BOREALIS



- Ideal para iluminar senderos de tránsito.
- Eficiencia de 160 Lm/w de consumo.
- Hasta 32,000lm de flujo luminoso.
- Protección certificada IP65.
- Tratamiento anticorrosivo y cobertura de pintura en polvo electrostática resistente a la intemperie.
- Chips **LUMILEDS Philips** con vida útil de 100,000 hrs.



## ACCESORIOS

### FOTOCELDA DE 3 PINES ON/OFF JL-207



VOLTAJE NOMINAL	120-277 VAC
FRECUENCIA OPERATIVA	50/60 Hz
HUMEDAD RELATIVA	96%
TEMPERATURA DE TRABAJO	-40 °C a +70°C
CARGA NOMINAL	100W a 1000W
NIVELES DE OPERACIÓN	16Lx ON / 24 Lx OFF
CONSUMO	0,5W MAX

### BASE FOTOCELDA DE 3 PINES ON/OFF JL-200



RANGO DE VOLTAJE SOPORTADO	0 a 480 VAC
FRECUENCIA OPERATIVA	50/60 Hz
CAPACIDAD DE CARGA	15 A
TEMPERATURA DE TRABAJO	-40 °C a +70°C
HUMEDAD RELATIVA	96%
LONGITUD DE CALIBRE INTEGRADO	15 CM. MIN.
CALIBRE CABLE	AWG#12/14/16 AWG#18 (non-UL)

## CONFIGURACIONES

CÓDIGO	POTENCIA	FLUJO LUMINOSO	TUBO DE MONTAJE
1KLABO030LD57U-A	30W	4,800LM	Ø 50MM
1KLABO035LD57U-A	35W	5,600LM	
1KLABO050LD57U-A	50W	8,000LM	
1KLABO055LD57U-A	55W	8,800LM	
1KLABO060LD57U-A	60W	9,600LM	
1KLABO065LD57U-B	65W	10,400LM	
1KLABO070LD57U-B	70W	11,200LM	
1KLABO080LD57U-B	80W	12,800LM	
1KLABO090LD57U-B	90W	14,400LM	
1KLABO095LD57U-B	95W	15,200LM	
1KLABO100LD57U-B	100W	16,000LM	
1KLABO105LD57U-C	105W	16,800LM	
1KLABO115LD57U-C	115W	18,400LM	
1KLABO120LD57U-C	120W	19,200LM	
1KLABO130LD57U-C	130W	20,800LM	
1KLABO135LD57U-C	135W	21,600LM	
1KLABO140LD57U-C	140W	22,400LM	
1KLABO145LD57U-C	145W	23,200LM	
1KLABO150LD57U-C	150W	24,000LM	
1KLABO155LD57U-D	155W	25,600LM	
1KLABO160LD57U-D	160W	24,800LM	
1KLABO165LD57U-D	165W	26,400LM	
1KLABO175LD57U-D	175W	28,000LM	
1KLABO180LD57U-D	180W	28,800LM	
1KLABO190LD57U-D	190W	30,400LM	
1KLABO200LD57U-D	200W	32,000LM	
			Ø 60MM



## ESPECIFICACIONES TÉCNICAS

MONTAJE	BRAZO EN POSTE/PUNTA DE POSTE
USO	EXTERIOR
MATERIAL DE FABRICACIÓN	CARCASA DE ALUMINIO VIDRIO TEMPLADO
MATERIAL DE LA ÓPTICA	POLICARBONATO
TORNILLERÍA	INOXIDABLE
TIPO DE LÁMPARA LED	LED SMD
TIPO DE LED	LUMILEDS PHILIPS SMD3030
TEMPERATURA DE COLOR	5700K
TENSIÓN DE RED	100-277 VCA
FACTOR DE POTENCIA	>0.90
EFICIENCIA	160 LM/W
TIPO DE CURVA	TIPO 2-M
ÍNDICE DE RENDIMIENTO CROMÁTICO	>70
TEMPERATURA DE OPERACIÓN	-30°C A 50°C
FRECUENCIA	AC 50/60 HZ
VIDA ÚTIL LED	100,000 HORAS L70
PROTECCIÓN ANTIBANDALISMO	IK 08
CLASIFICACIÓN DE VIBRACIÓN	3 G

## DIAGRAMA

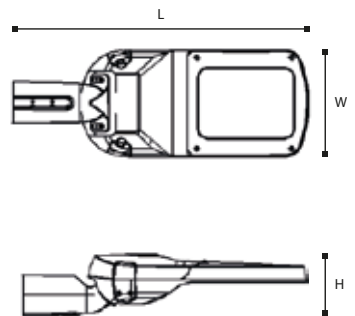

## CERTIFICACIONES



IP65



## DIMENSIONES (CM)

POTENCIA	H	W	L
30W - 60W	11.5	20	55.8
65W - 100W	11.5	23.3	61.2
105W - 150W	11.5	26	67.5
155W - 200W	12	32	77.5

**MATRIZ**  
**Gómez Palacio, Durango.**

Servicio al cliente  
011 52 871 750 00 03  
011 52 871 750 00 79  
011 52 871 750 11 52  
011 52 871 750 11 62

Correo Electrónico  
ventas@alcodm.com.mx

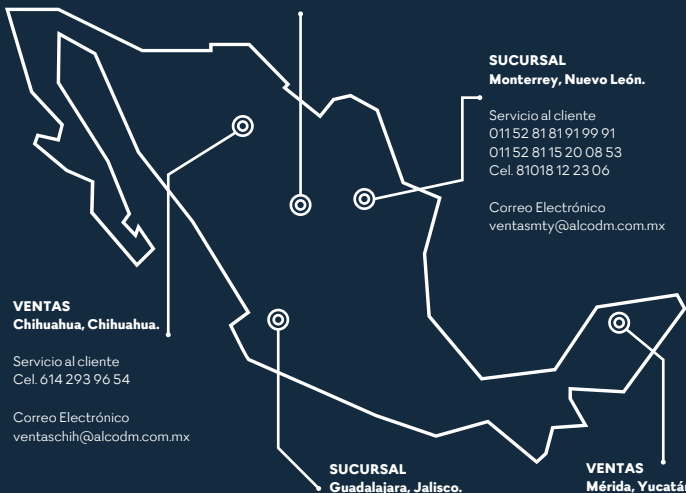

**SUCURSAL**  
**Monterrey, Nuevo León.**

Servicio al cliente  
011 52 81 81 91 99 91  
011 52 81 15 20 08 53  
Cel. 81018 12 23 06

Correo Electrónico  
ventasmt@alcodm.com.mx

**VENTAS**  
**Chihuahua, Chihuahua.**

Servicio al cliente  
Cel. 614 293 96 54

Correo Electrónico  
ventaschi@alcodm.com.mx

**SUCURSAL**  
**Guadalajara, Jalisco.**

Servicio al cliente  
011 52 33 13 68 80 28  
011 52 33 31 62 08 75  
Cel. 33 16 12 60 22

Correo Electrónico  
ventasgdl@alcodm.com.mx

**VENTAS**  
**Mérida, Yucatán.**

Servicio al cliente  
Cel. 99 94 45 62 12

Correo Electrónico  
ventasmid01@alcodm.com.mx



ventas@alcodm.com.mx | direcciongeneral@alcodm.com.mx  
sugerenciasquejas@alcodm.com.mx



Alcodm alcodm\_ @alcodm alcodm mx

www.alcodm.com.mx